

Fitting instructions

Make: Jeep

Wrangler; 2006->

Type: 4573

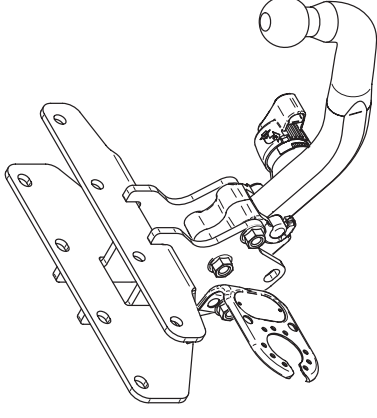
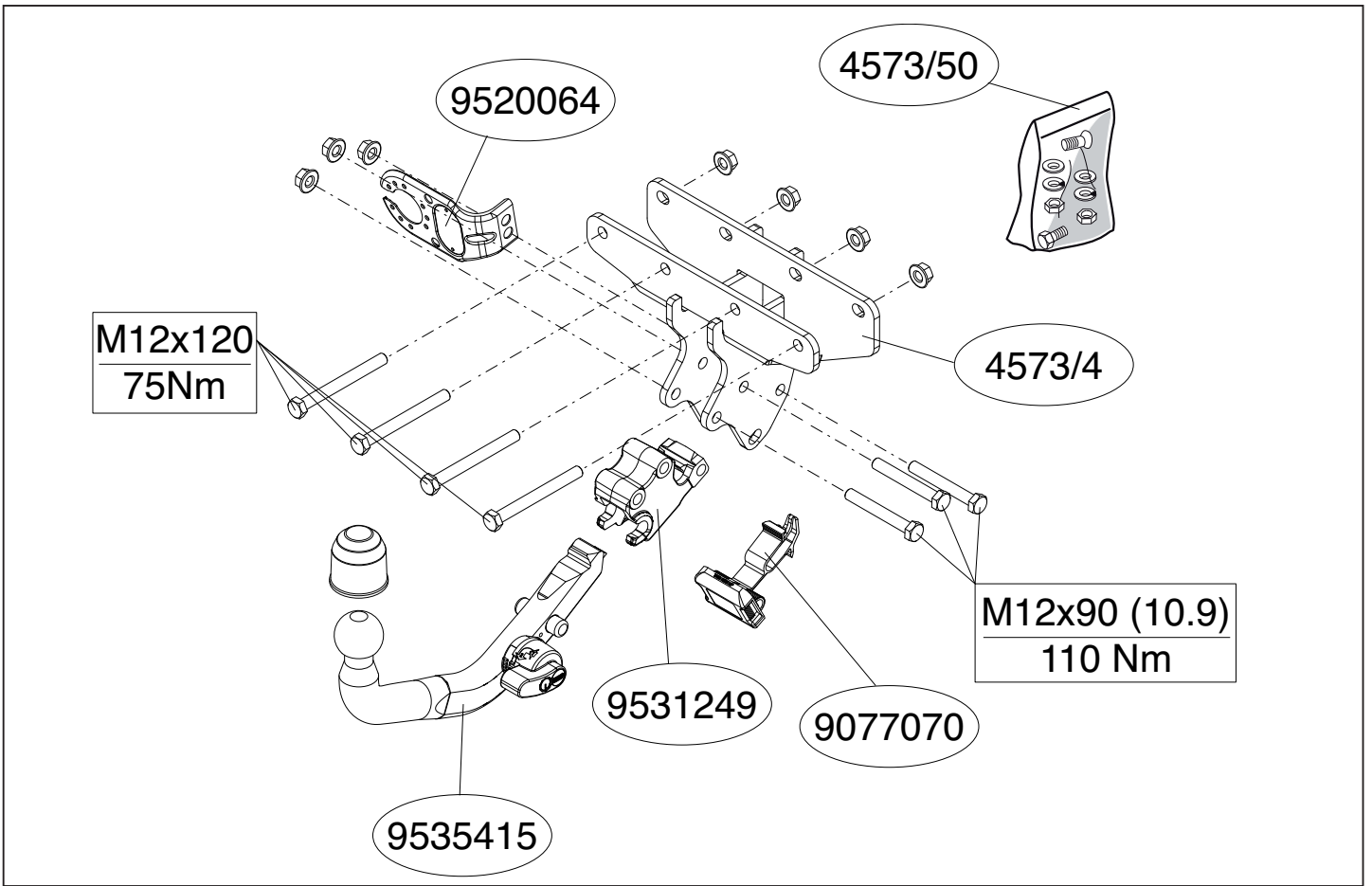



© 457370MN/08-05-2008/1

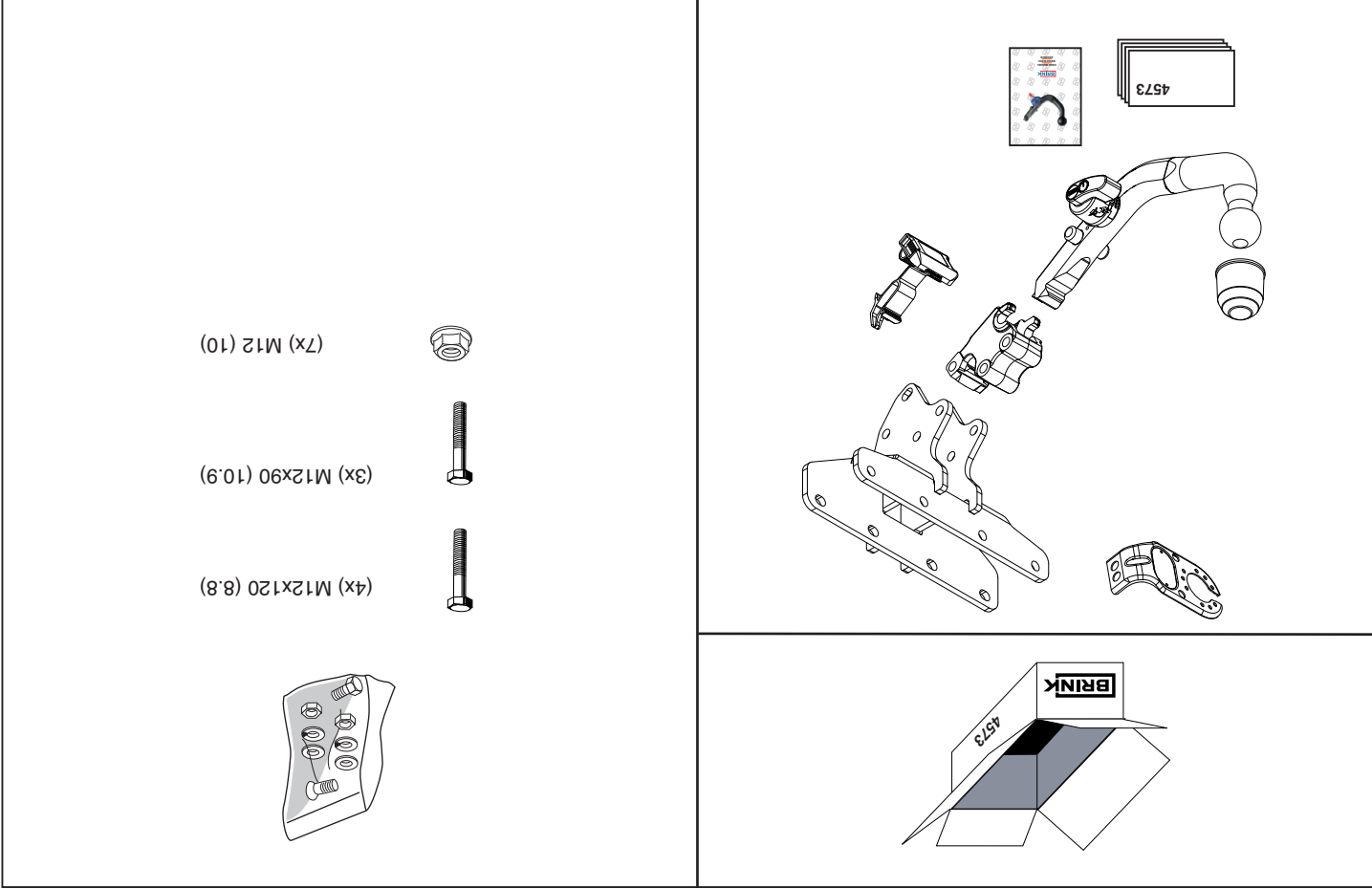

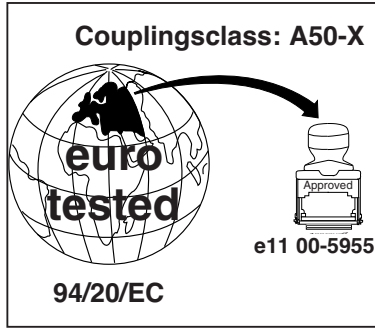
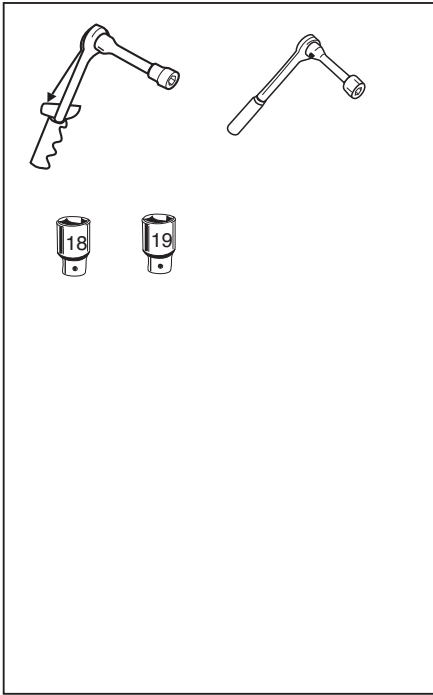

D-Value : 15,3 kN

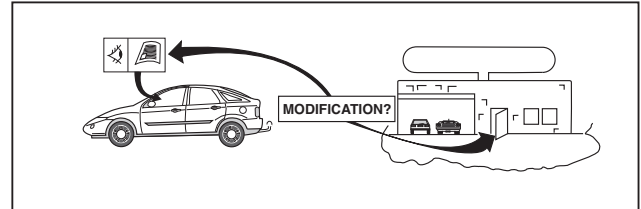
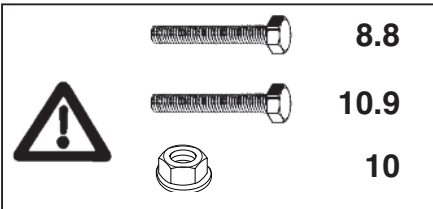
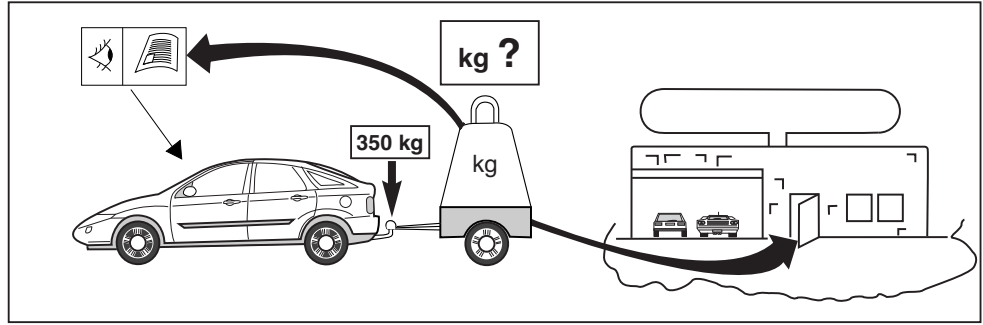

© 457370MN/08-05-2008/3



Dispositivo di traino tipo: 4573
 Per autoveicoli: Jeep Wrangler; 2006->
 Tipo funzionale: JK 72/74

Classe e tipo di attacco: A50-X
 Omologazione: e11 00-5955
 Valore D: 15,3 kN
 Carico Verticale max. S: 350 kg
 Larghezza rimorchiabile per Caravan e T.A.T.S.: 2,45m vedere CARTA di CIRCOLAZIONE VEICOLO (motrice) + 70 cm = ..arrotondare ai 5 cm superiore (vedi D.M.28/05/85)
 Massa rimorchiabile: vedi carta di circolazione dell' autoveicolo

Per verificare l'idoneità del dispositivo di traino omologato a norma CEE 94/20, all'installazione sulla vettura su cui si intende procedere al montaggio, compilare la seguente formula (se necessario declassare la massa rimorchiabile):

$$D = \frac{T \times C}{T + C} \times 0,00981 \leq 15,3 \text{ kN}$$

dove: T= Massa Complessiva Max. della motrice (in kg)
 C= Massa Rimorchiabile Max. della motrice (in kg)

DA COMPILARE PER IL COLLAUDO

DICHIARAZIONE DI CORRETTO MONTAGGIO: la sottoscritta Ditta dichiara di aver montato in maniera corretta ed in conformi/ alle prescrizioni sia del costruttore del veicolo che del costruttore del dispositivo stesso il seguente dispositivo di attacco meccanico:

tipo:.....
 Il dispositivo di attacco sopra indicato è stato installato su autoveicolo
 modello:.....
 targa:.....
 Data:.....

TIMBRO e FIRMA

Si dichiara inoltre di aver informato l'utente del veicolo sull'USO e MANUTENZIONE del dispositivo stesso.

© 457370MN/08-05-2008/8

* Die für das Fahrzeug zugelassene Anhängelast ist den Fahrzeug Unterlagen zu entnehmen. Bei Änderungen des Fahrzeuggewichtes muß die höchstzulässige Anhängelast gegebenenfalls aus dem D-Wert nachgerechnet werden.
* Elektrische Anlage gemäß StVZO anbringen.
Auskunft hierüber kann Ihr Fachhändler oder der TÜV geben.

HINWEISE:

* Should this installation process entail the cutting of the bumper – conformation **MUST** be obtained by the installation engineer of the customer's acceptance prior to completion. Brink International do not accept responsibility for any matters arising as a result of this miscommunication.

NOTE:

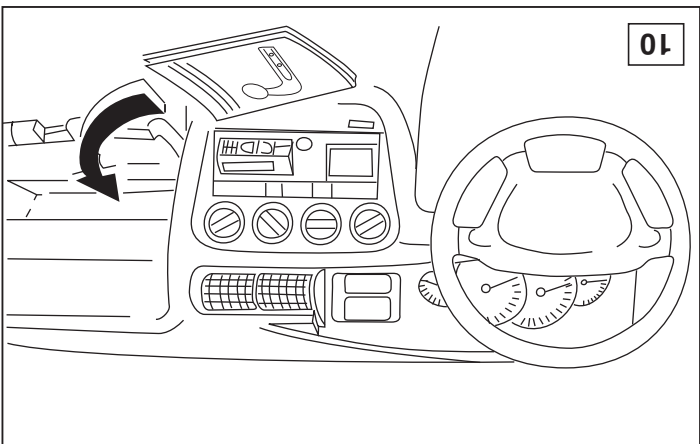
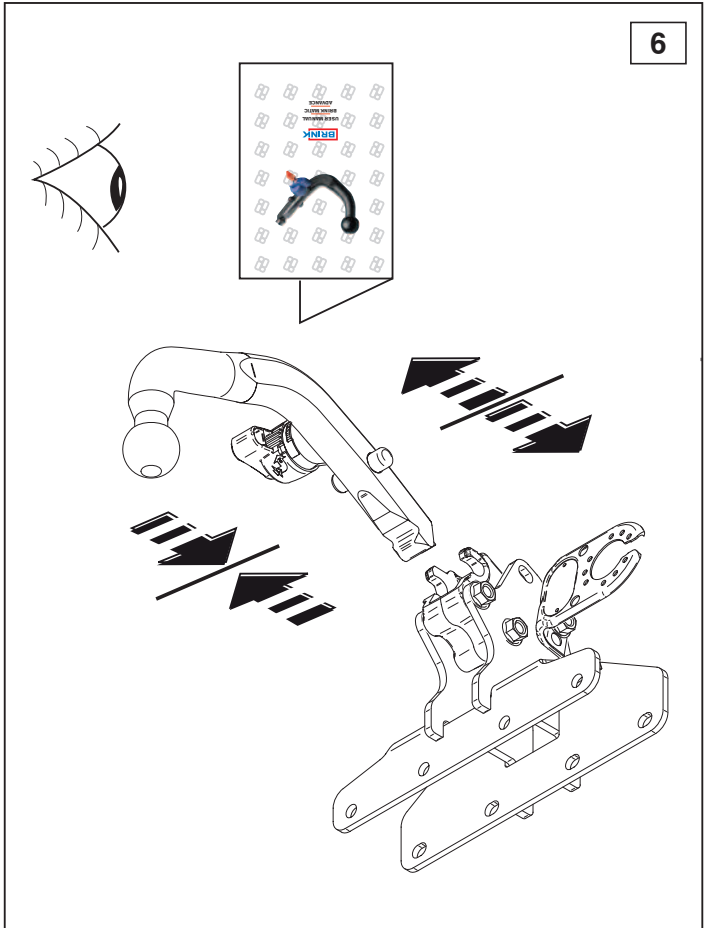
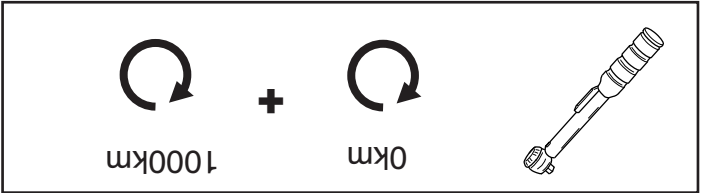

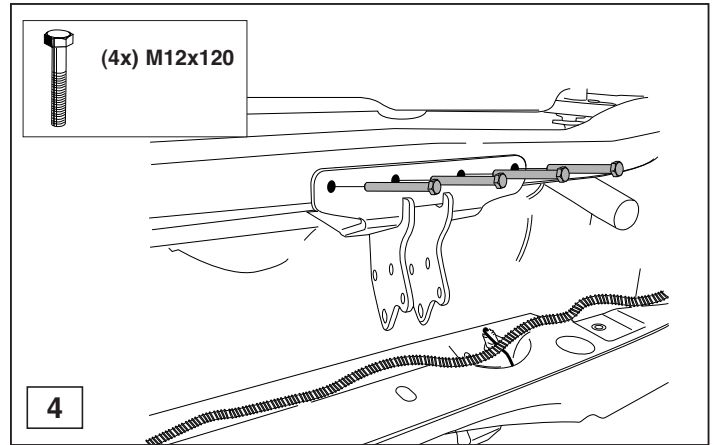
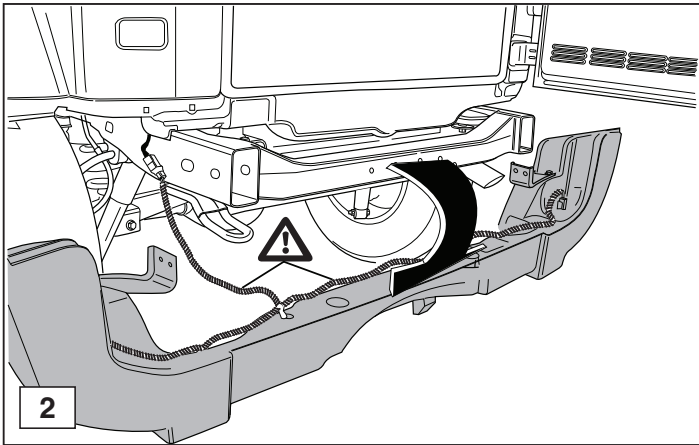
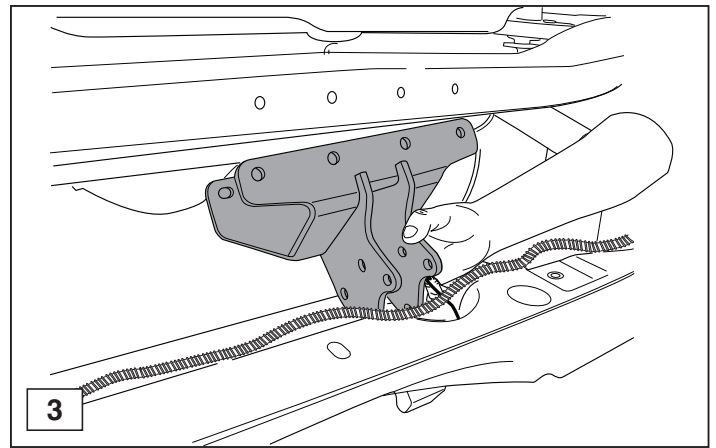
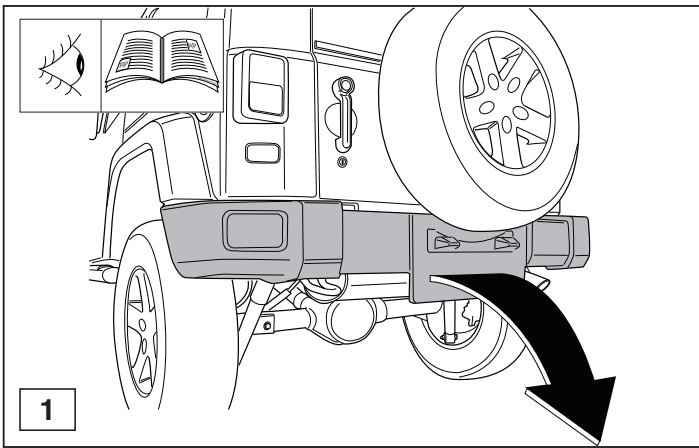

© 457370MN/08-05-2008/5

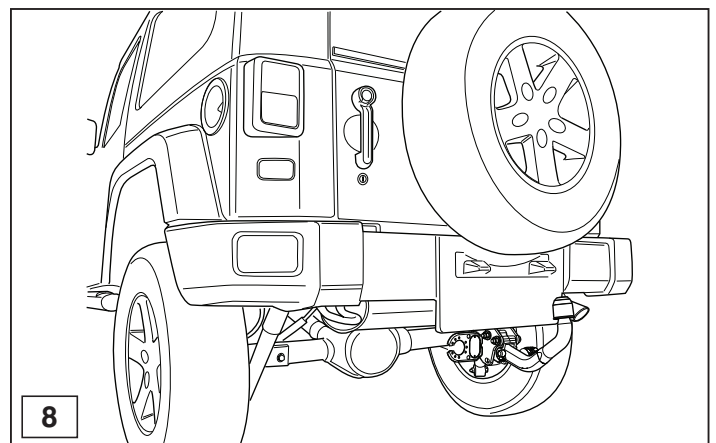
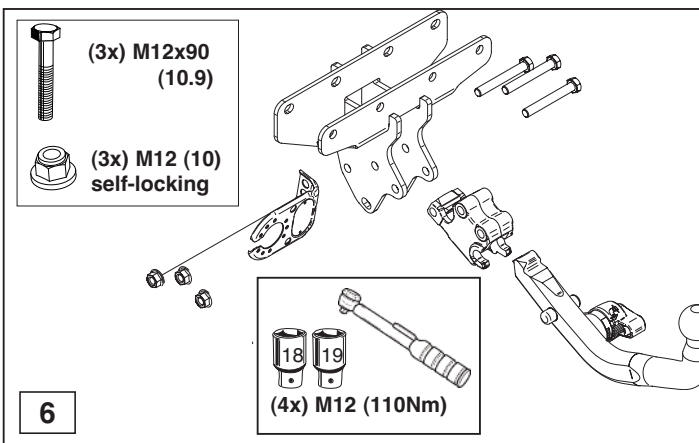
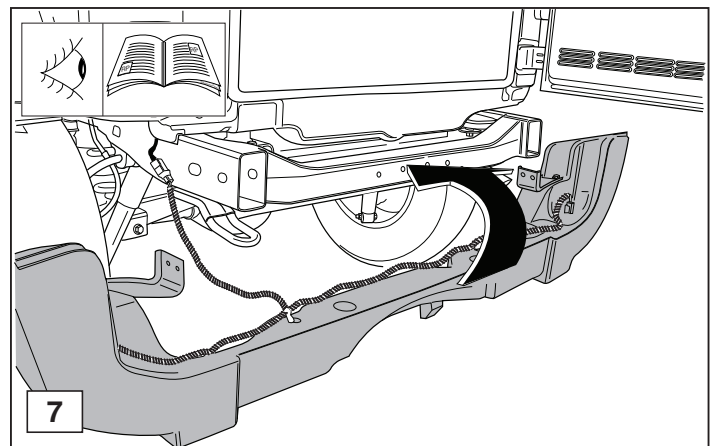
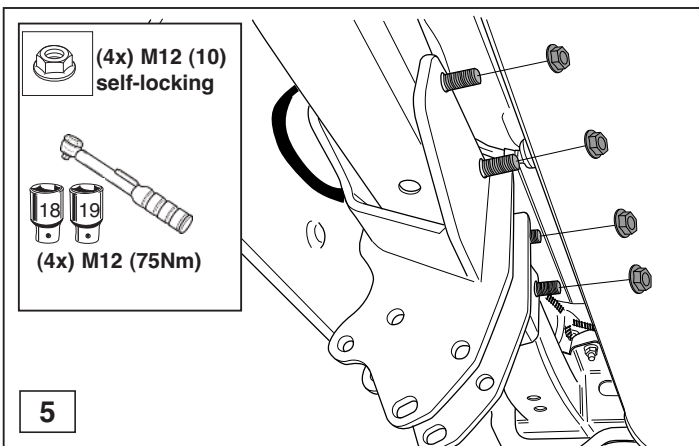

© 457370MN/08-05-2008/6