

---

Fitting instructions

---

Make: Peugeot

---

206 Sportbumper; 1998->

---

206 +; 2008->

---

Type: 4069

---

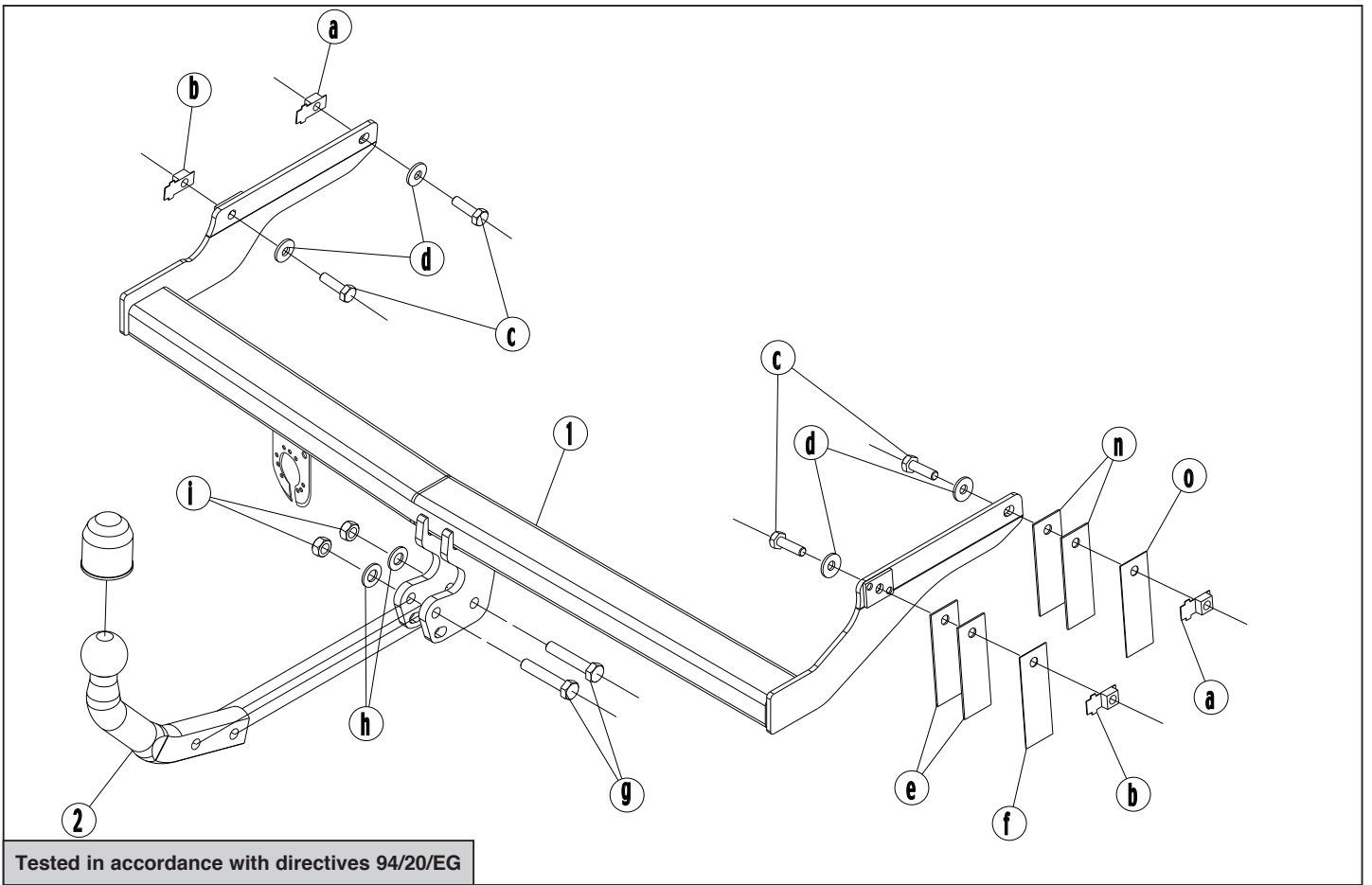

Tested in accordance with directives 94/20/EG

© 406970/11-02-2009/1

© 406970/11-02-2009/14

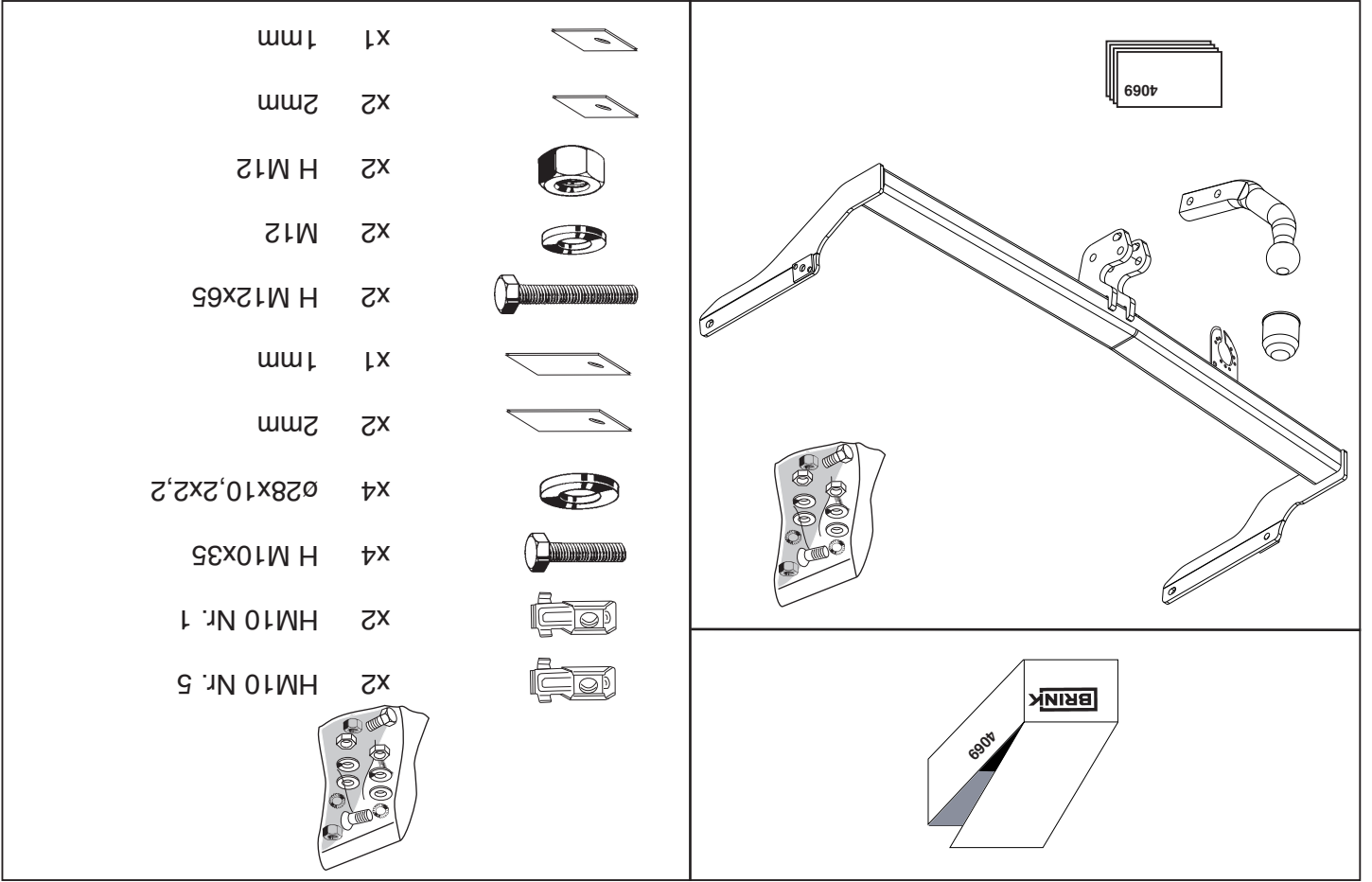

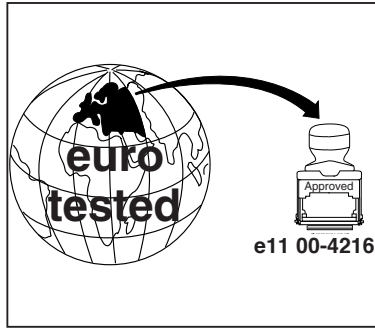
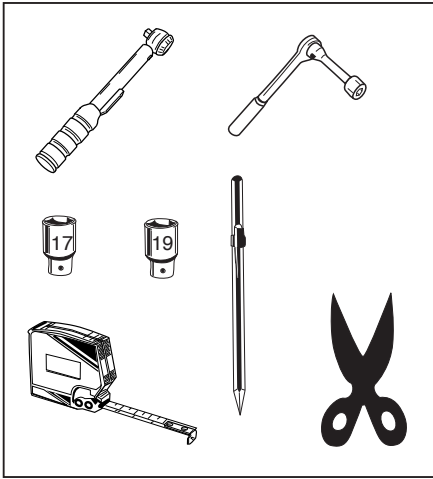

**D= 6,4 kN**

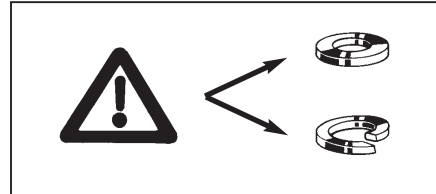
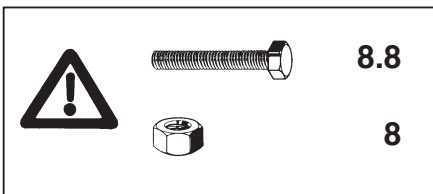
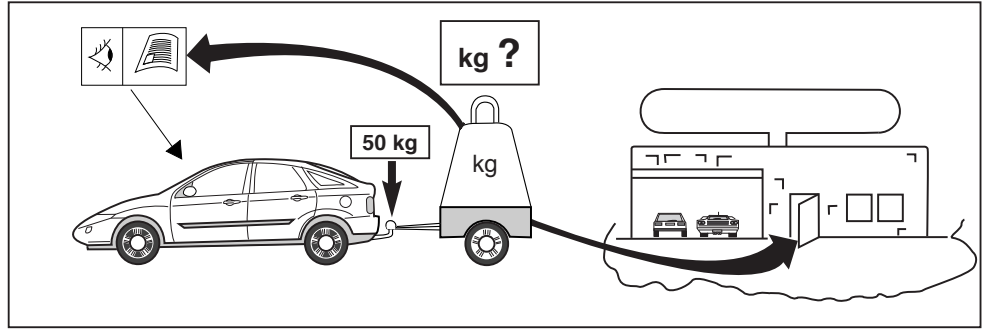

© 406970/11-02-2009/3

Dispositivo di traino tipo: 4069  
 Per autoveicoli: Peugeot 206Sportbumper; 1998-> / 206+; 2008->  
 Tipo funzionale: 2A, 2C, 2D, 2H, 2J, 2L, 2M, 2S, 2T and 2U.

Classe e tipo di attacco: A50-X  
 Omologazione: e11 00-4216  
 Valore D: 6,4 kN  
 Carico Verticale max. S: 50 kg  
 Larghezza rimorchiabile per Caravan e T.A.T.S.: 2,45m vedere CARTA di CIRCOLAZIONE VEICOLO (motrice) + 70 cm = ..arrotondare ai 5 cm superiore (vedi D.M.28/05/85)  
 Massa rimorchiabile: vedi carta di circolazione dell' autoveicolo

**Per verificare l'idoneità del dispositivo di traino omologato a norma CEE 94/20, all'installazione sulla vettura su cui si intende procedere al montaggio, compilare la seguente formula (se necessario declassare la massa rimorchiabile):**

$$D = \frac{T \times C}{T + C} \times 0,00981 \leq 6,4 \text{ kN}$$

dove: T= Massa Complessiva Max. della motrice (in kg)  
 C= Massa Rimorchiabile Max. della motrice (in kg)

**DA COMPILARE PER IL COLLAUDO**

**DICHIARAZIONE DI CORRETTO MONTAGGIO:** la sottoscritta Ditta dichiara di aver montato in maniera corretta ed in conformit' alle prescrizioni sia del costruttore del veicolo che del costruttore del dispositivo stesso il seguente dispositivo di attacco meccanico:

tipo:.....  
 Il dispositivo di attacco sopra indicato è stato installato su autoveicolo  
 modello:.....  
 targa:.....  
 Data:.....

**TIMBRO e FIRMA**

Si dichiara inoltre di aver informato l'utente del veicolo sull'USO e MANUTENZIONE del dispositivo stesso.

© 406970/11-02-2009/12

# 206 RC

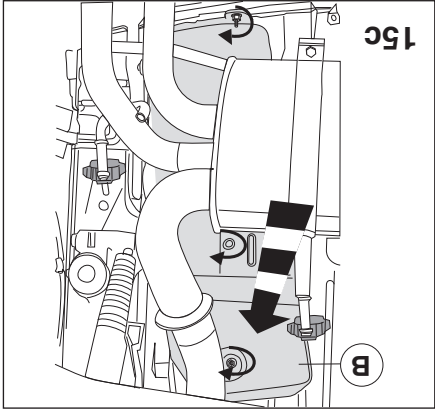
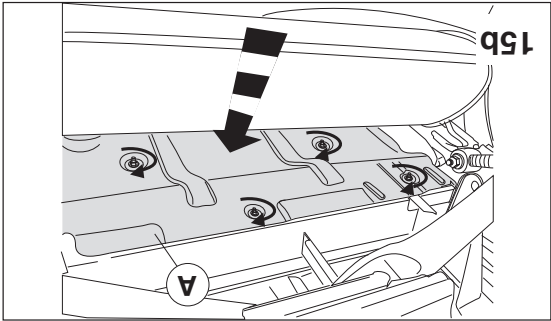
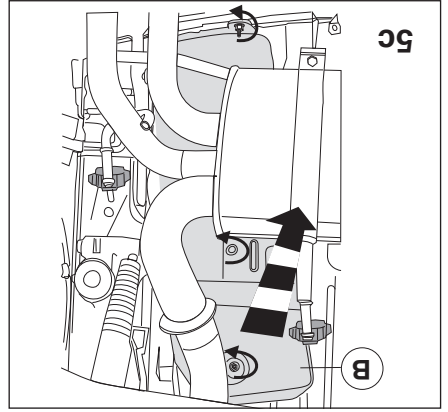
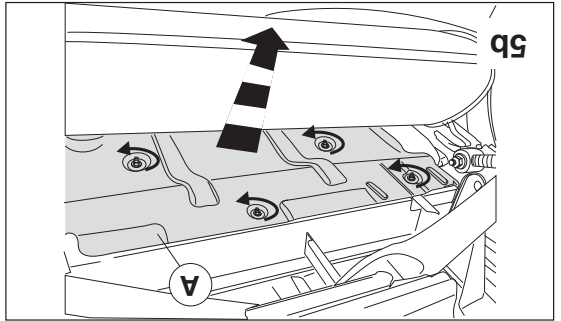
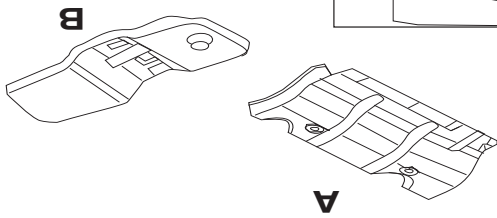

© 406970/11-02-2009/11

## Torque settings for nuts and bolts (8.8)

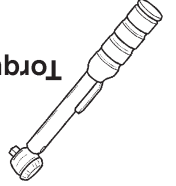

M10 46 Nm 41Nm (with self-locking nut)



M12 79 Nm 71Nm (with self-locking nut)



### HINWEISE:

\* Die für das Fahrzeug zugelassene Anhängelast ist den Fahrzeug Unterlagen zu entnehmen. Bei Änderungen des Fahrzeuggewichtes muß die höchstzulässige Anhängelast gegebenenfalls aus dem D-Wert nachgerechnet werden.  
 \* Auskunft hierüber kann ihr Fachhändler oder der TÜV geben.  
 \* Elektrische Anlage gemäß StVZO anbringen.

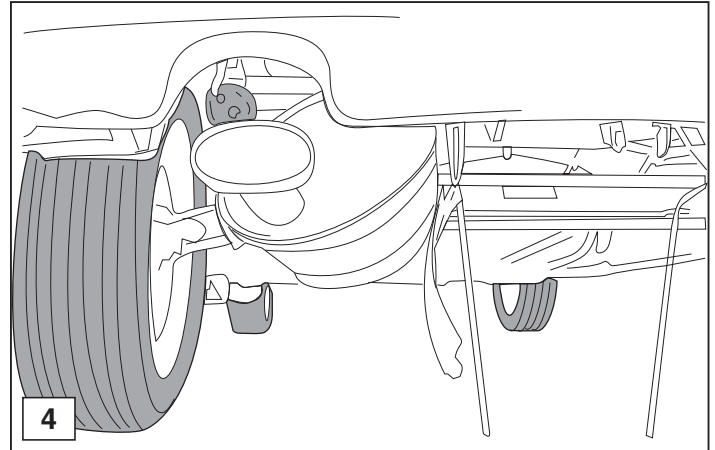
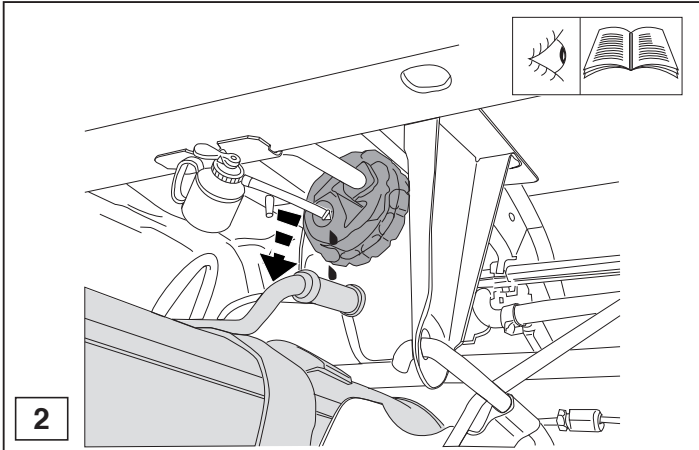
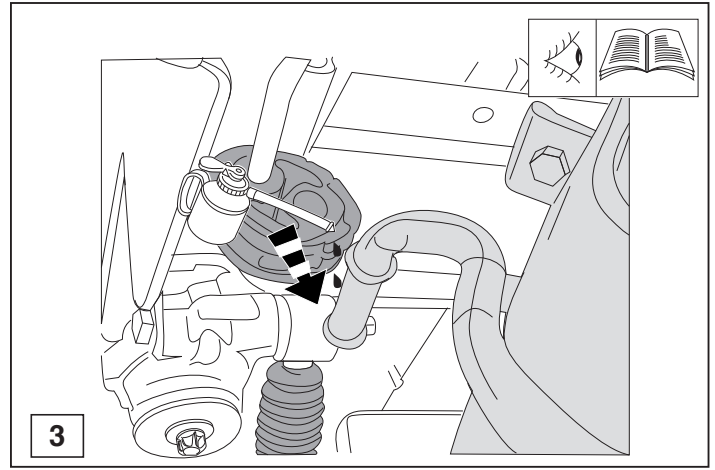
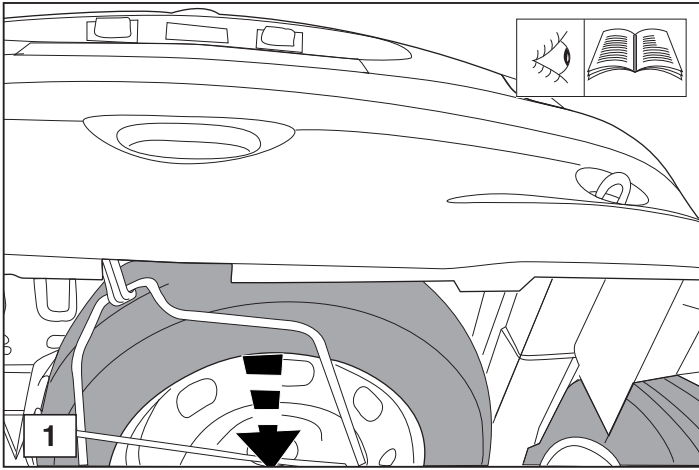

© 406970/11-02-2009/5

## 206 RC

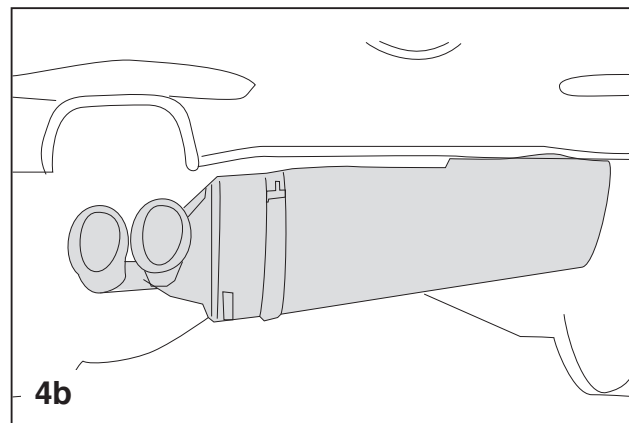
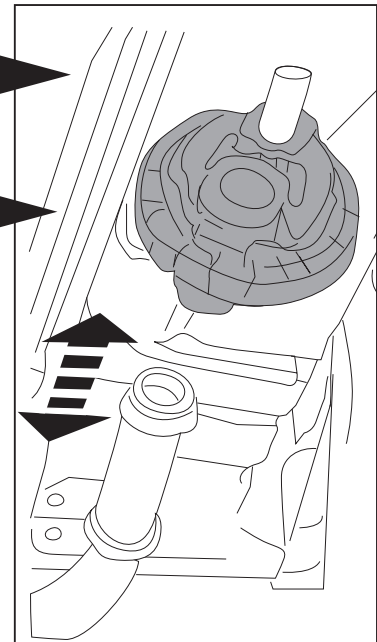
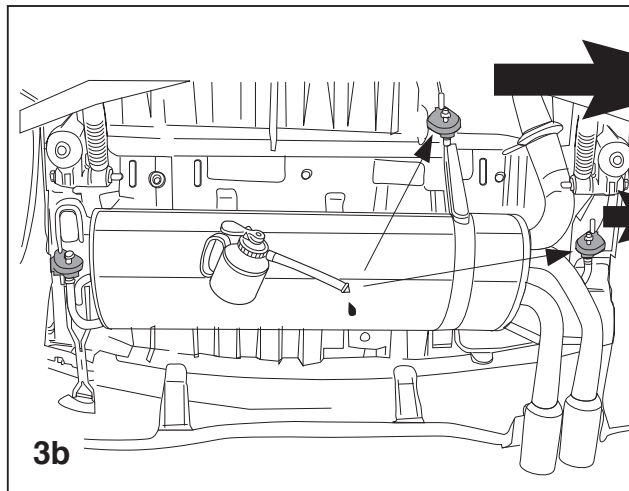

© 406970/11-02-2009/10

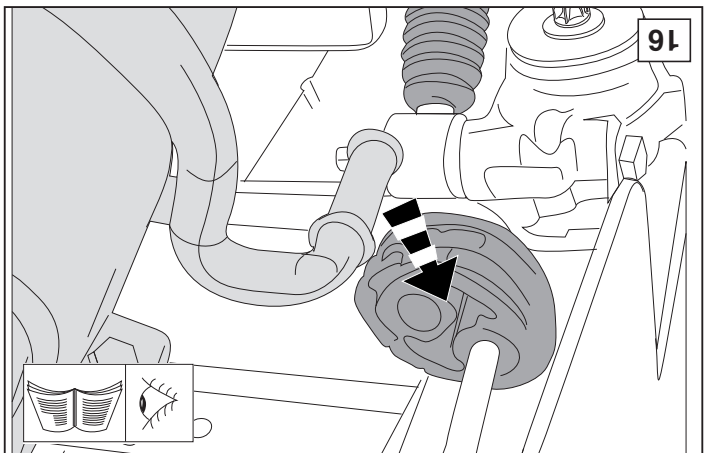
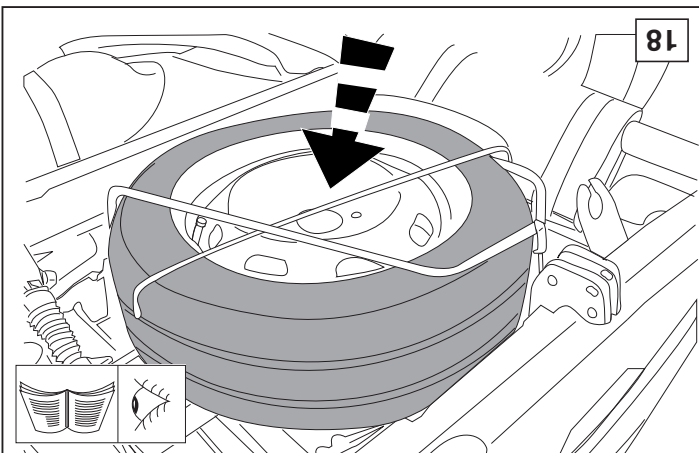
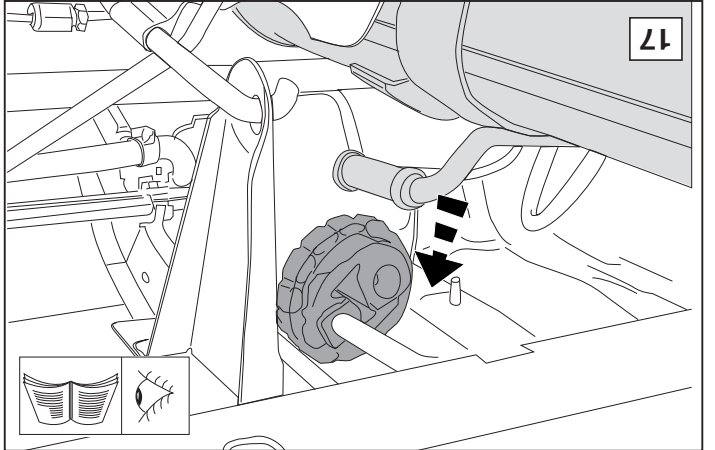
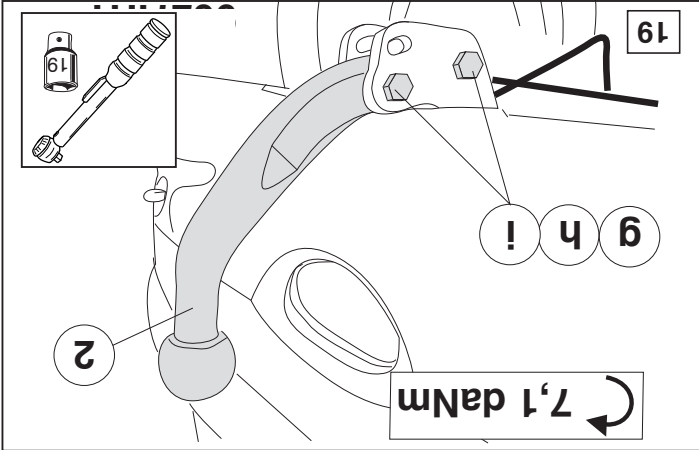
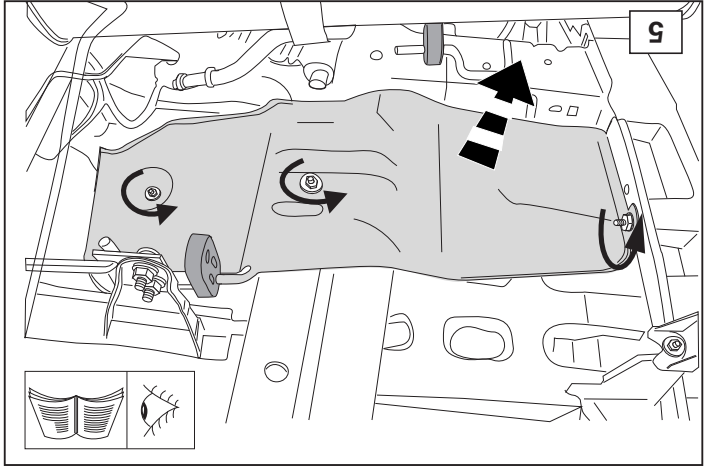
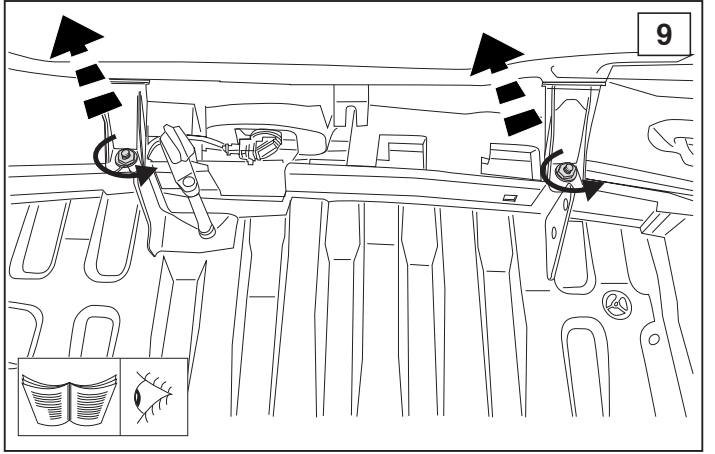
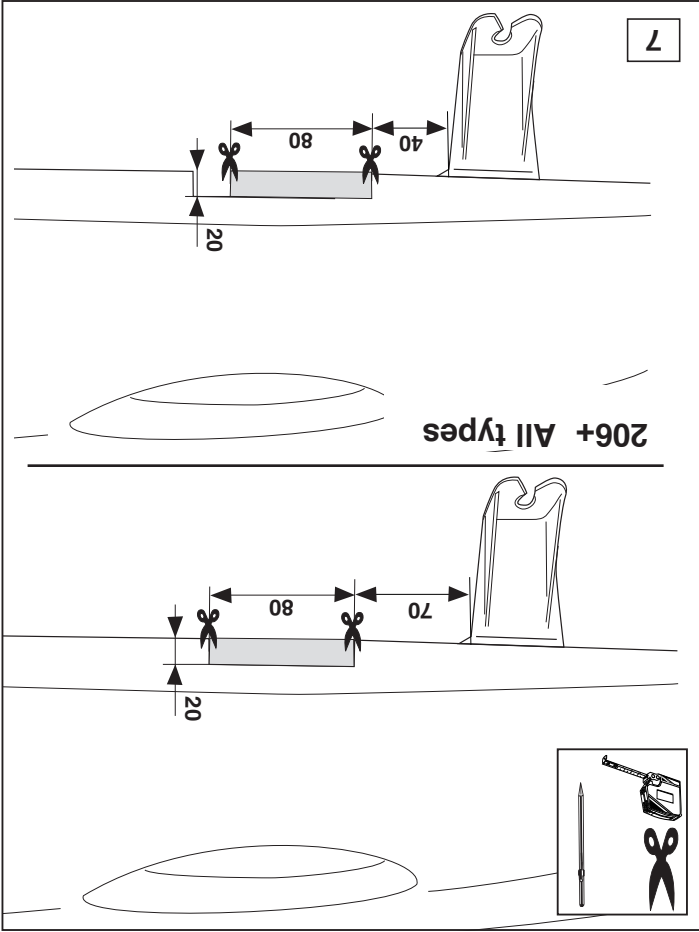

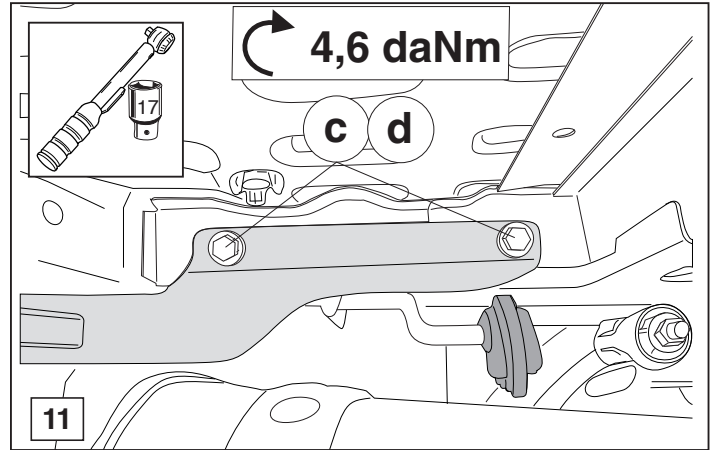
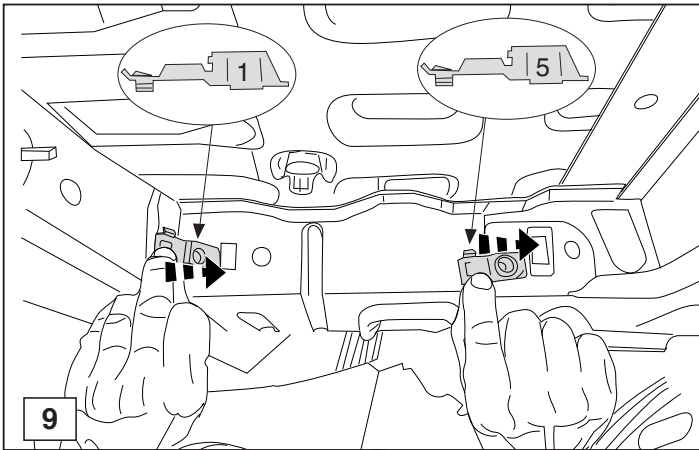
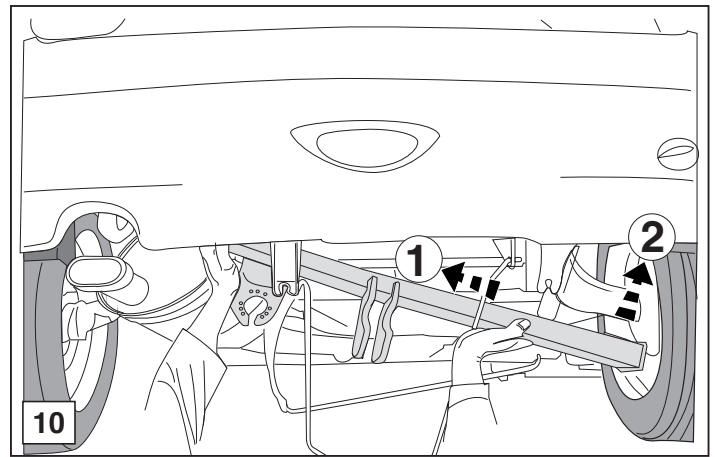
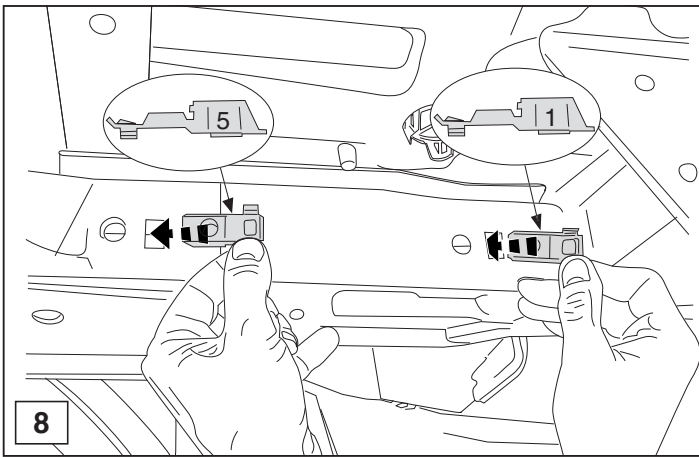

© 406970/11-02-2009/7

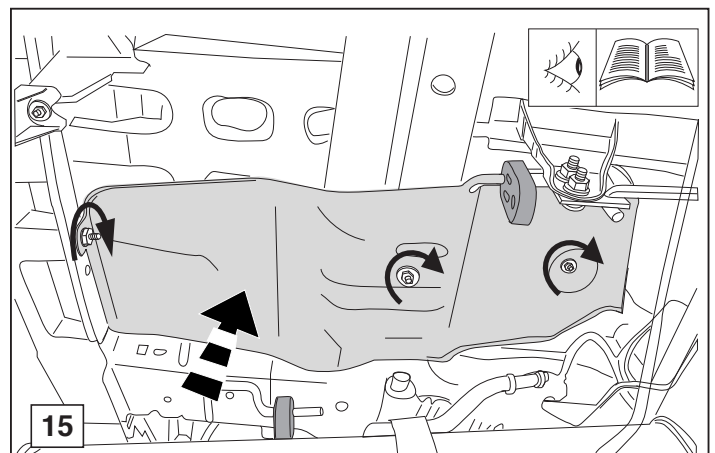
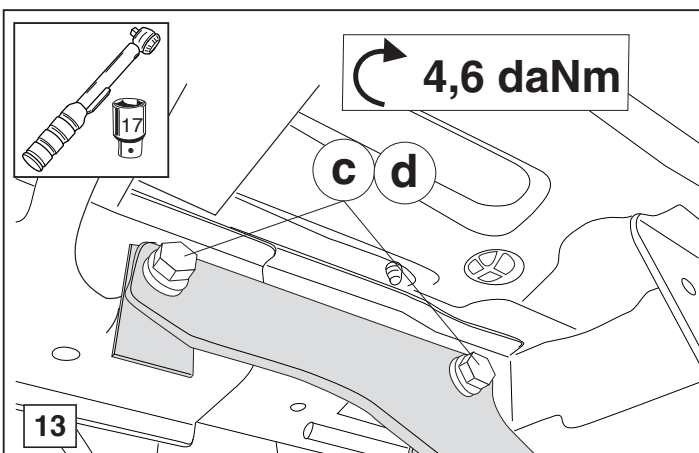
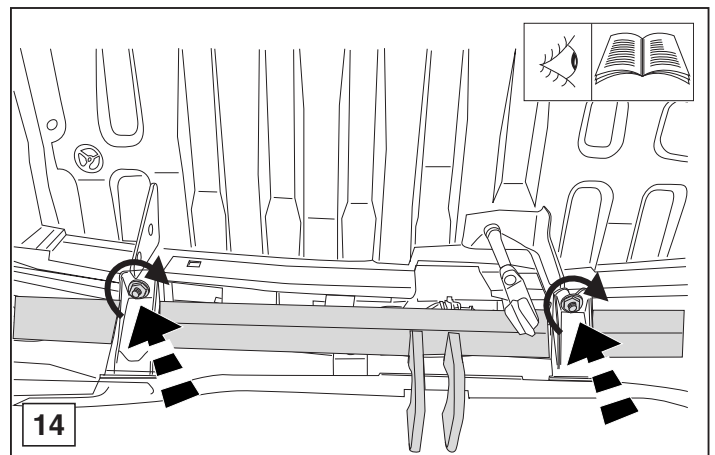
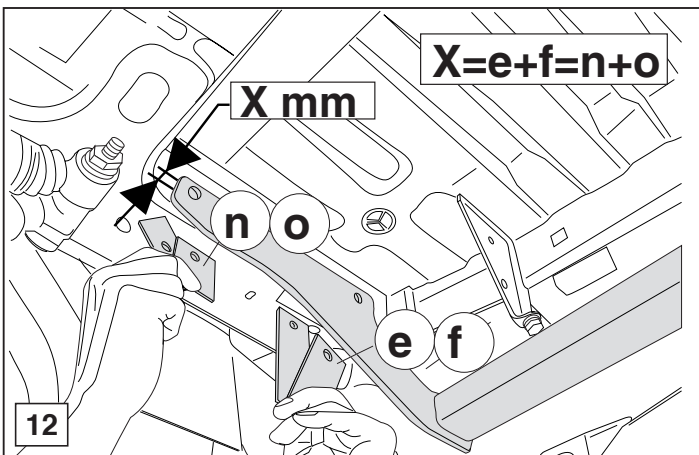

© 406970/11-02-2009/8